

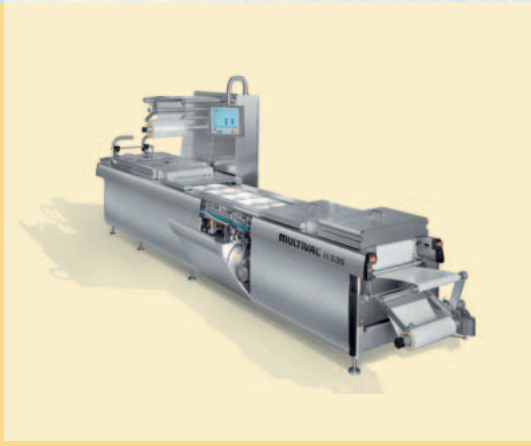

Clean in Place. CIP.

The automatic cleaning system
by Multivac.



MULTIVAC
BETTER PACKAGING

CIP. Faster, safer, and precisely reproducible.



Hardly anything is more important than hygiene. Especially when it comes to food products. But the cleaning of packaging machines is elaborate and is usually only carried out on the exterior. Here Multivac is setting a new standard in hygiene – Clean in Place, abbreviated as: CIP. The automatic cleaning system quickly and safely cleans and disinfects components on the interior of your Multivac packaging machine that have previously been difficult or impossible to reach. The manual cleaning of the machine's exterior parts is integrated in the CIP cleaning process at the same time.

Reproducible, documentable and traceable. The CIP cleaning process.

The cleaning with CIP is carried out according to a program that is individually defined for your machine and which can be protocolled precisely. The advantage that you get from this: maximum hygiene that is reproducible at any time. Good for you, since you save time and can enjoy safety by means of an overall cost-efficient and yet environmentally friendly cleaning, which satisfies even the most stringent hygiene demands. And it's good for the functional efficiency of your machine, since wear and tear or negative influences caused by deposits will be largely excluded. – This is only offered at Multivac.



CIP. Good reasons for the cleanest solution.

More hygiene, less effort.

Two cleaning and disinfection materials ensure absolute cleanliness – for the removal of fat, protein and other organic matters just as much as of limestone and other deposits. It's an automatic process that is gentle for you and your machine. CIP sets a new standard in protocolled and documented hygiene and thoroughness. And this with a much lower effort for you.

Clean at the push of a button.

The high-quality components of the cleaning system ensure the highest automated reliability of all procedures. They increase your productivity and reduce costs and risks.

Inside and outside.

CIP not only ensures the exact, process-controlled cleaning of interior machine surfaces that are difficult to access. Through a connected manual lance, the manual cleaning of the exterior surfaces is integrated into the CIP program and thus is carried out according to the strict requirements of the highest hygiene standard. All in one stroke.

Flexible and individual.

You have the choice between already developed programs optimized by Multivac, such as a water rinse, alkaline or acidic cleaning with or without manual cleaning and disinfection. But you can also define your own individual cleaning program. The access rights to your program are restricted to the servicing officials by means of a password. A machine operator can only start the program but not change it. That means more security for your production and cleaning processes.

- 1 Space for three chemical holders with collecting trays
 - Alkaline cleaning fluid against grease, proteins and other organic substances
 - Acidic cleaning fluid against deposits such as limescale
 - Disinfectants
- 2 Three suction guns with low-level and empty container notification
- 3 Injector block
- 4 Pressure increase pump
- 5 Connections with quick coupling or screw cap
 - Water supply and drainage
 - Compressed air
 - Electricity
 - Control cable
- 6 Hose with spray gun and two different nozzles
- 7 Maintenance unit for water supply with filter, pressure regulator and pipe isolator

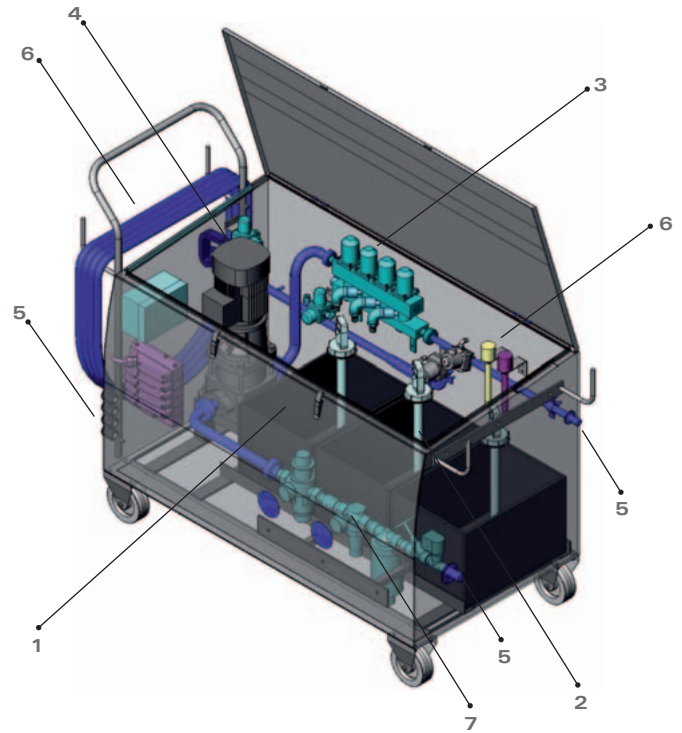

The CIP supply unit.

The mobile system supplies the individual CIP circuits with water, cleaning and disinfection materials. The valves are activated through the controls of the thermoforming machine. After the cleaning, the CIP supply unit can simply be disconnected and can be attached to another packaging machine if desired.

Package more and for a longer time with your packaging machine. With CIP.

1

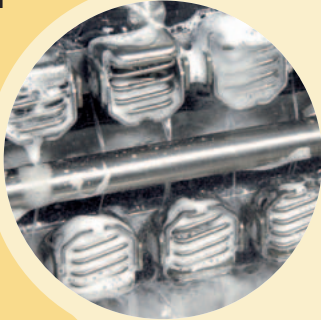

We have developed CIP components for you that simplify the cleaning of your Multivac packaging machine for you, satisfy the most stringent hygiene requirements, dispense the cleaning and disinfecting materials in a cost-efficient and environmentally friendly way, and contribute to your problem-free use of your Multivac for many years. Because the more thorough the cleaning, the longer the lifespan.

1 Transport chain (CIP chain)

In contrast to the traditional chain rinse with water, this cleaning is chemical. That increases the lifespan of the chain.

2

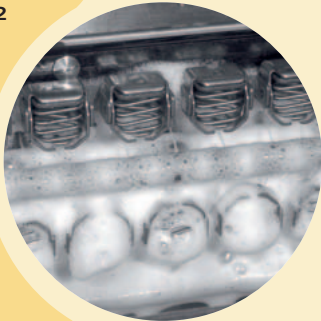

2 Chain guide profile (CIP chain guides)

This CIP module supports the perfect automatic chain cleaning.

3

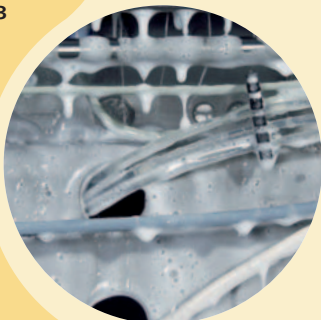

3 Lateral frame profile (CIP frame)

The lateral frame is thoroughly cleaned without disassembly.

4



4 Machine interior (CIP inside)

Reliable cleaning of the complete interior space of the machine and areas that are difficult to access, such as moulds, infeeding stretch, sealing tools and cutting.

5

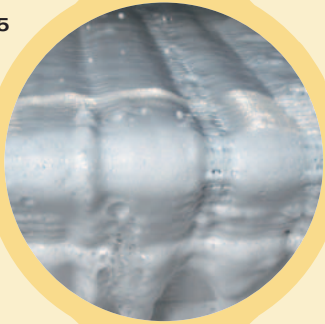

5 Cleaning of the removal belt (CIP intralox conveyor)

The automatic cleaning is carried out quickly and safely while the belt is running.





www.multivac.com